

INNOVATIONS OF GREAT VALUE

PLANETARY GEARBOXES FOR SERVOMOTORS
ZF-SERVOPLAN PG

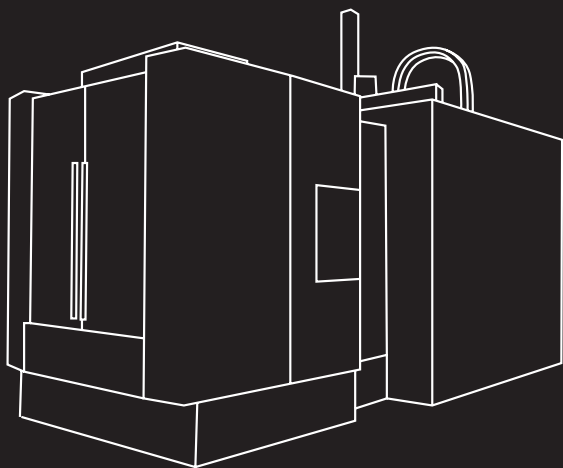



Content

HIGHLY ACCURATE GEARS	Page 3
WIDE RANGE OF SERVOGEARBOXES	Page 4
ONE-STAGE PLANETARY GEARBOX	Page 5-6
TWO-STAGE PLANETARY GEARBOX	Page 7-8
GEARBOX OUTPUT SHAFT	Page 9
CONFIGURATION AND SELECTION	Page 10
ORDER NO. AND QUOTATION REQUEST	Page 11-12
ZF WORLDWIDE	Page 13-14

THE EXPERT FOR THE INDUSTRY

Our enthusiasm for innovative products and processes and our uncompromising pursuit of quality have made us a global leader in driveline and chassis technology as well as active and passive safety technology. We are contributing towards a sustainable future by producing advanced technology solutions with the goal of improving mobility, increasing the efficiency of our products and systems, and conserving resources. Our customers in the automotive and industrial sectors welcome our determined focus on products and services, which provide great customer value.

LOW-PLAY GEARING FOR EXACT POSITIONING



Precise, dynamic, and even robust and compact represent the outstanding characteristics which are required for servogearboxes in industrial automation. Servoplan PG perfectly meets these requirements.

The ZF-Servoplan planetary gearbox series has been designed for direct mounting onto servomotors. The available wide range of sizes and the use of a modular system allows the application in almost any field of automation.

The combination of servomotors with ZF-Servoplan planetary gearboxes constitutes a coaxial drive unit. The servomotor output shaft is connected to the sun gear of the gearbox by using a clamping coupling. The sun gear drives three planetary gears inside the planetary carrier, which rotate inside the internal ring gear.

Since the power is distributed to three planetary gears, thereby distributing the forces evenly, this allows a very compact design with high power density.

Planetary gearsets for automation technology can be used in many applications. 1 and 2-stage servo drives with ZF-Servoplan servogearboxes are applied

wherever highly dynamic and exact positioning is required. Target output torques of 25 to 3 000 Nm are possible with different model sizes. Planetary gearsets for servomotors are used for packaging technology, in shaping technology, as well as generally for machines and facilities.

ZF-Servoplan servogearboxes are working in a highly precise manner, with great dynamics, and guarantee exact and accurate reproducibility. Machinery energy costs are decreasing thanks to the servogearboxes' high level of efficiency.

Machinery featuring such equipment is operated in a maintenance-free manner and thus secures stable production processes.

WIDE RANGE The servogearboxes can be used in almost all areas of automation technology thanks to their modular design.

- 1 The robust output shaft shoulder allows the highest possible axial loads
- 2 High radial forces and an extreme tilt resistance through large-dimensioned taper roller bearings
- 3 A high positional accuracy is achieved by using ground and highly accurate gears
- 4 High quality Viton shaft seals ensure a permanent and save sealing
- 5 High torsional rigidity thanks to an optimized sungear with a stable two-sided support for the planetary gears
- 6 Low running noise thanks to an optimized gear tooth shape
- 7 Compact design by using separated output bearings
- 8 A special galvanic surface treatment makes the housing environmentally resistant, even under the most adverse conditions
- 9 Hermetically sealed housing by using robust sealed screws
- 10 Special surface treatment of the ring gear in order to optimize the lubrication supply of the teething
- 11 High acceleration torques permissible by using gearbox internal interlocking power transmission
- 12 Low gearbox temperatures and minimum power loss by using smallest possible seal diameters
- 13 Backlash-free power transmission by using clamping coupling for motor shaft connection

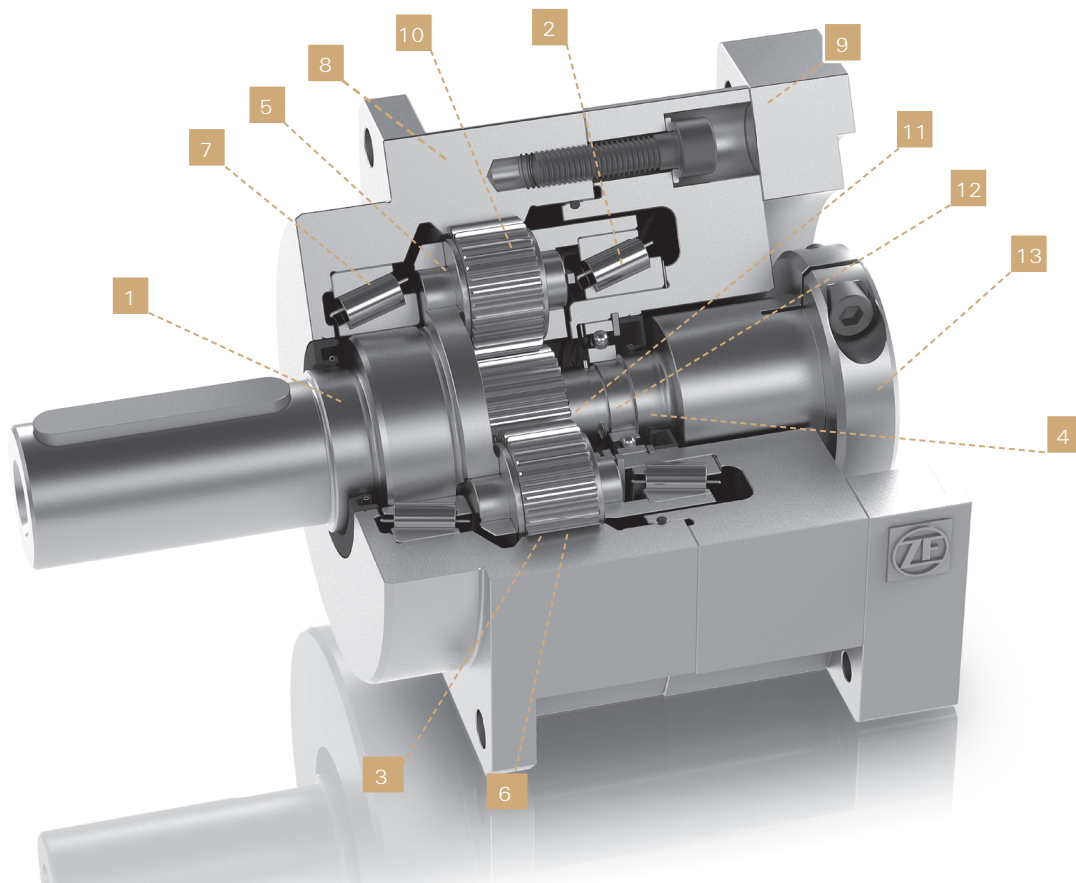

ONE-STAGE PLANETARY GEARBOX

		i	PG 25/1	PG 100/1	PG 200/1	PG 500/1	PG 1200/1	PG 3000/1
Nominal output torque Also applicable for S1 operation	T_{2N} [Nm]	3	-	-	120	280	720	1 800
		4	25	85	170	420	1 020	2 500
		5	25	100	200	500	1 200	3 000
		7	25	85	170	420	1 020	2 500
		10	20	60	120	280	720	1 800
Emergency stop torque ¹⁾	T_{2Not} [Nm]	3	-	-	400	840	2 160	5 400
		4	100	280	560	1 260	3 060	7 500
		5	100	330	660	1 500	3 600	9 000
		7	80	280	560	1 260	3 060	7 500
		10	80	200	400	840	2 160	5 400
Max. acceleration torque ²⁾	T_{2B} [Nm]	3	-	-	220	560	1 440	3 000
		4	50	170	340	840	2 040	5 000
		5	50	200	400	1 000	2 400	6 000
		7	50	170	340	840	2 040	5 000
		10	40	110	220	560	1 440	3 000
Max. input speed ⁵⁾	n_{1Max} [rpm]	3	-	-	4 000	3 200	2 500	2 000
		4	5 000	5 000	4 000	3 200	2 500	2 000
		5	6 300	6 300	5 000	4 000	3 200	2 500
		7	8 000	8 000	6 300	5 000	4 000	3 000
		10	10 000	10 000	8 000	6 300	5 000	3 500
Nominal input speed	n_{1N} [rpm]	3	-	-	2 300	1 800	1 300	800
		4	3 000	3 000	2 500	2 000	1 500	1 000
		5	4 000	4 000	3 000	2 500	2 000	1 200
		7	5 000	5 000	4 000	3 000	2 500	1 500
		10	6 000	6 000	5 000	4 000	3 000	2 000
Backlash standard reduced ³⁾	[arcmin]		≤ 6	≤ 6	≤ 4	≤ 4	≤ 4	≤ 4
			≤ 3	≤ 3	≤ 2	≤ 2	≤ 2	≤ 2
Torsional rigidity	C_t [Nm/arcmin]		3.5	8.2	24	48	149	340
Moment of inertia	I₁ [kg cm²]	3	-	-	2.8	8.2	36	128
		4	0.16	0.55	2.0	6.75	24.5	97.6
		5	0.16	0.47	1.64	5.54	18.8	76.4
		7	0.15	0.41	1.36	4.59	14.5	59.9
		10	0.14	0.38	1.22	4.1	12.3	51.1
Max. axial force	F_A [N]		3 200	4 500	7 000	10 000	15 000	22 000
Max. radial force ⁴⁾	F_R [N]		2 700	3 700	6 700	9 200	14 000	21 000
Lifetime	L_h [h]		> 20 000	> 20 000	> 20 000	> 20 000	> 20 000	> 20 000
Efficiency	η		≥ 97%	≥ 97%	≥ 97%	≥ 97%	≥ 97%	≥ 97%
Weight	m [kg]		1.6	2.9	5.7	11.5	27	62
Operating noise ⁶⁾	L_p [dB(A)]		≤ 53	≤ 56	≤ 56	≤ 56	≤ 65	≤ 65
Lubrication	Lifetime lubrication, closed system							
Surface protection	Aluminium, respectively steel, galvanically treated							
Installation position	Any, variable							
Operating temperature	-10 °C to +90°C							
Direction of rotation	same as input							
Degree of protection	IP 65							

1) Max. 1 000 times during gearbox lifetime.

2) At a maximum of 1 000 cycles per hour. Percentage of the overall running time less than 5% and duration of the impulse under 0.3 sec.

3) Optional

4) Resultant force at center of output shaft and at output speed 300 rpm.

5) For cyclic duty only

6) i = 10, n_{an} = 3 000 rpm

Dimensions [mm]		PG 25/1	PG 100/1	PG 200/1	PG 500/1	PG 1200/1	PG 3000/1
DR		M5	M8	M12	M16	M20	M20
D1 (g6)		60	70	90	130	160	200
D2		20	28	40	45	60	95
D3 (k6)		16	22	32	40	55	85
D4		5.5	6.6	9	11	13	17
D5		68	85	120	165	215	290
D6 * (F7)	min.	6	14	19	24	32	42
	max.	14	24	32	38	48	60
L1 *		129.5	155.7	193.1	245.6	290	399.5
L2 (+0,5)		28	36	58	82	82	130
L3		20	20	30	30	30	40
L4		7.7	8	10	12.5	22	30
L6 *	min.	15	23	30	32	45	55
	max.	30	40	50	60	82	110
L7 *		3.5	4.5	5.5	5.3	8	8
L11		62	76	101	141	182	242
L12		2	2	2	3	3	3
L13 *	min.	62	80	106	141	182	242
L14		22	28	50	70	70	110
L15		3	4	4	5	5	7.5
L16		5	6	10	12	16	22
L17		18	24.5	35	43	59	90
L22 *		4.5	7.5	8.5	7.5	9	10

D7 / D 8 / D9

Adaptations available for all common servomotors, dimensions are variable.

* Dimensions depending on motor
Please use page 12 for inquiries and orders.

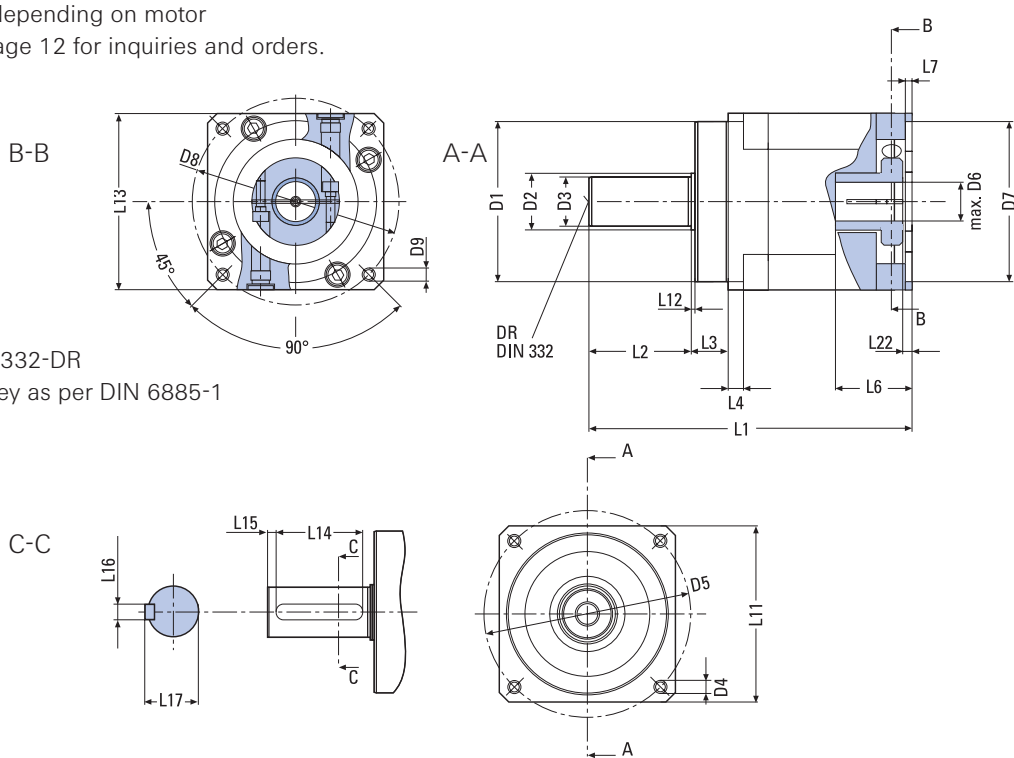

Centering DIN 332-DR
Optional with key as per DIN 6885-1

TWO-STAGE PLANETARY GEARBOX

		i	PG 25/2	PG 100/2	PG 200/2	PG 500/2	PG 1200/2
Nominal output torque Also applicable for S1 operation	T_{2N} [Nm]	20, 35, 40, 70	25	85	170	420	1 020
		25, 50	25	100	200	500	1 200
		100	20	60	120	280	720
Emergency stop torque ¹⁾	T_{2Not} [Nm]	20, 35, 40, 70	100	280	560	1 260	3 060
		25, 50	100	330	660	1 500	3 600
		100	80	200	400	840	2 160
Max. acceleration torque ²⁾	T_{2B} [Nm]	20, 35, 40, 70	50	170	340	840	2 040
		25, 50	50	200	400	1 000	2 400
		100	40	110	220	560	1 440
Max. input speed ⁵⁾	n_{1Max} [rpm]	20, 25, 35,	6 300	6 300	5 000	4 000	3 200
		40, 50, 70, 100	10 000	10 000	8 000	6 300	5 000
Nominal input speed	n_{1N} [rpm]	20, 25, 35,	4 000	4 000	3 000	2 500	2 000
		40, 50, 70, 100	6 000	6 000	5 000	4 000	3 000
Backlash standard reduced ³⁾	[arcmin]		≤ 8	≤ 8	≤ 6	≤ 6	≤ 6
			≤ 6	≤ 6	≤ 4	≤ 4	≤ 4
Torsional rigidity	C_t [Nm/arcmin]		3.5	8.2	24	48	149
Moment of inertia	I₁ [kg cm²]	20	0.12	0.47	1.56	5.29	6.95
		25	0.12	0.47	1.54	5.25	6.70
		35	0.12	0.47	1.53	5.21	6.53
		40	0.10	0.47	1.44	4.96	5.51
		50	0.10	0.47	1.44	4.96	5.45
		70	0.10	0.46	1.44	4.94	5.42
	100	0.10	0.46	1.44	4.94	5.39	
Max. axial force	F_A [N]		3 200	4 500	7 000	10 000	15 000
Max. radial force ⁴⁾	F_R [N]		2 700	3 700	6 700	9 200	14 000
Lifetime	L_h [h]		> 20 000	> 20 000	> 20 000	> 20 000	> 20 000
Efficiency	η		≥ 94%	≥ 94%	≥ 94%	≥ 94%	≥ 94%
Weight	m [kg]		2.2	3.8	7.5	15	35
Operating noise ⁶⁾	L_p [dB(A)]		≤ 49	≤ 51	≤ 55	≤ 55	≤ 63
Lubrication	Lifetime lubrication, closed system						
Surface protection	Aluminium, respectively steel, galvanically treated						
Installation position	Any, variable						
Operating temperature	-10 °C to +90°C						
Direction of rotation	same as input						
Degree of protection	IP 65						

- 1) Max. 1 000 times during gearbox lifetime.
- 2) At a maximum of 1 000 cycles per hour. Percentage of the overall running time less than 5% and duration of the impulse under 0.3 sec.
- 3) Optional
- 4) Resultant force at center of output shaft and at output speed 300 rpm.
- 5) For cyclic duty only
- 6) i = 10, n_{en} = 3 000 rpm



For installation drawings, please reference:
www.zf.com/industrial-drives

Dimensions [mm]		PG 25/2	PG 100/2	PG 200/2	PG 500/2	PG 1200/2
DR		M5	M8	M12	M16	M20
D1 (g6)		60	70	90	130	160
D2		20	28	40	45	60
D3 (k6)		16	22	32	40	55
D4		5.5	6.6	9	11	13
D5		68	85	120	165	215
D6 * (F7)	min.	6	11	14	19	19
	max.	14	24	32	38	38
L1 *		153	182.2	236	296	335.2
L2 (+0,5)		28	36	58	82	82
L3		20	20	30	30	30
L4		7.7	8	10	12.5	22
L6 *	min.	15	23	30	32	45
	max.	30	40	50	60	82
L7 *		3.5	4.5	5.5	5.3	8
L11		62	76	101	141	182
L12		2	2	2	3	3
L13 *	min.	62	80	106	141	182
L14		22	28	50	70	70
L15		3	4	4	5	5
L16		5	6	10	12	16
L17		18	24.5	35	43	59
L22 *		4.5	7.5	8.5	7.5	9

D7 / D 8 / D9

Adaptations available for all common servomotors, dimensions are variable.

* Dimensions depending on motor
Please use page 12 for inquiries and orders.

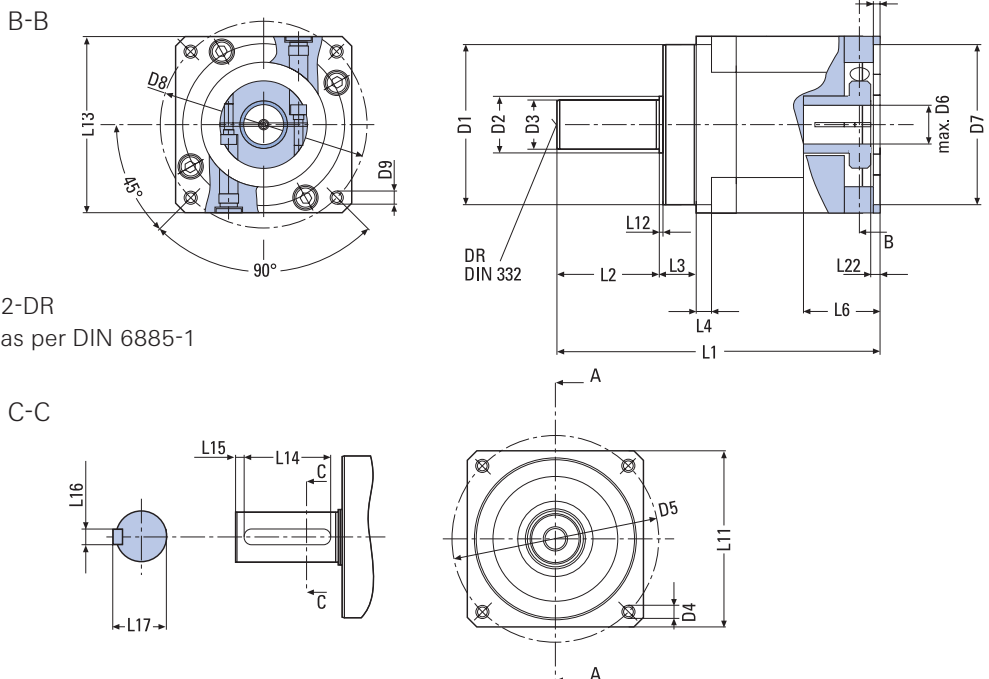

Centering DIN 332-DR
Optional with key as per DIN 6885-1

GEARBOX OUTPUT SHAFT

The gearbox output shaft is available in the following designs:

Plain output shaft (standard) for shrunk, backlash-free shaft-hub connections. This allows lower levels of running (operating) noise. We recommend the use of output shafts with shrunk shaft-hub connections.

Alternatively available:

Output shaft with key as per DIN 6885-1 for keyed shaft-hub connections. This type of connection is suitable for constant direction, where applications, requirements are not as stringent. This connection type requires additional axial fixing of the hub. A centering bore with thread is provided on the face end of the gearbox output shaft for this purpose (as per DIN 332-DR).

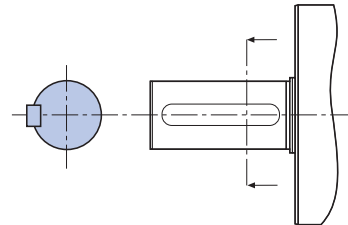
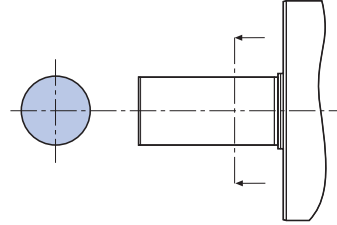

		PG 25/1 25/2	PG 100/1 100/2	PG 200/1 200/2	PG 500/1 500/2	PG 1200/1 1200/2	PG 3000/1
Thread		M5	M8	M12	M16	M20	M20
T_A	[Nm]	5.5	23	79	130	260	260
F_V (= Pretensioning Force)	[kN]	6.5	17	40	50	80	80
K min.	[mm]	0.8	1.4	1.4	0.8	0.8	1.4
K max.	[mm]	1.0	1.6	1.6	1.0	1.0	1.6

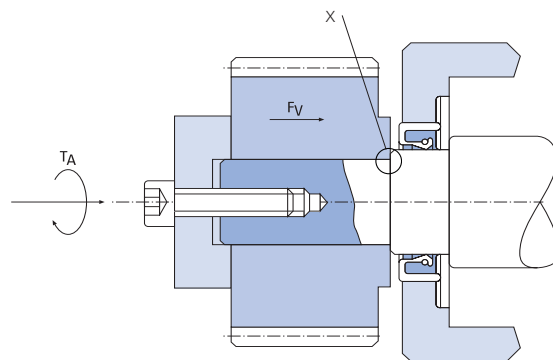
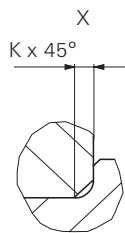

The connecting part on the gearbox output shaft must have a chamfer „K“ (see table) on the contact pattern to the gearbox.

CONFIGURATION AND SELECTION

Fast gearbox selection

The quickest and most reliable method, to determine the appropriate gearbox size for a specific application, is a comparison of motor peak torque with gearbox data. Applications are differentiated based on norm EN 60034-1 as to continuous duty (S1) or intermittent cyclic duty (S4/S5). For intermittent cyclic duties the maximum motor acceleration torque is relevant, whereas for continuous duties motor nominal torque is used. In case the motor peak torque exceeds the permitted gearbox values, a calculation based on the actual application specific torques is required.

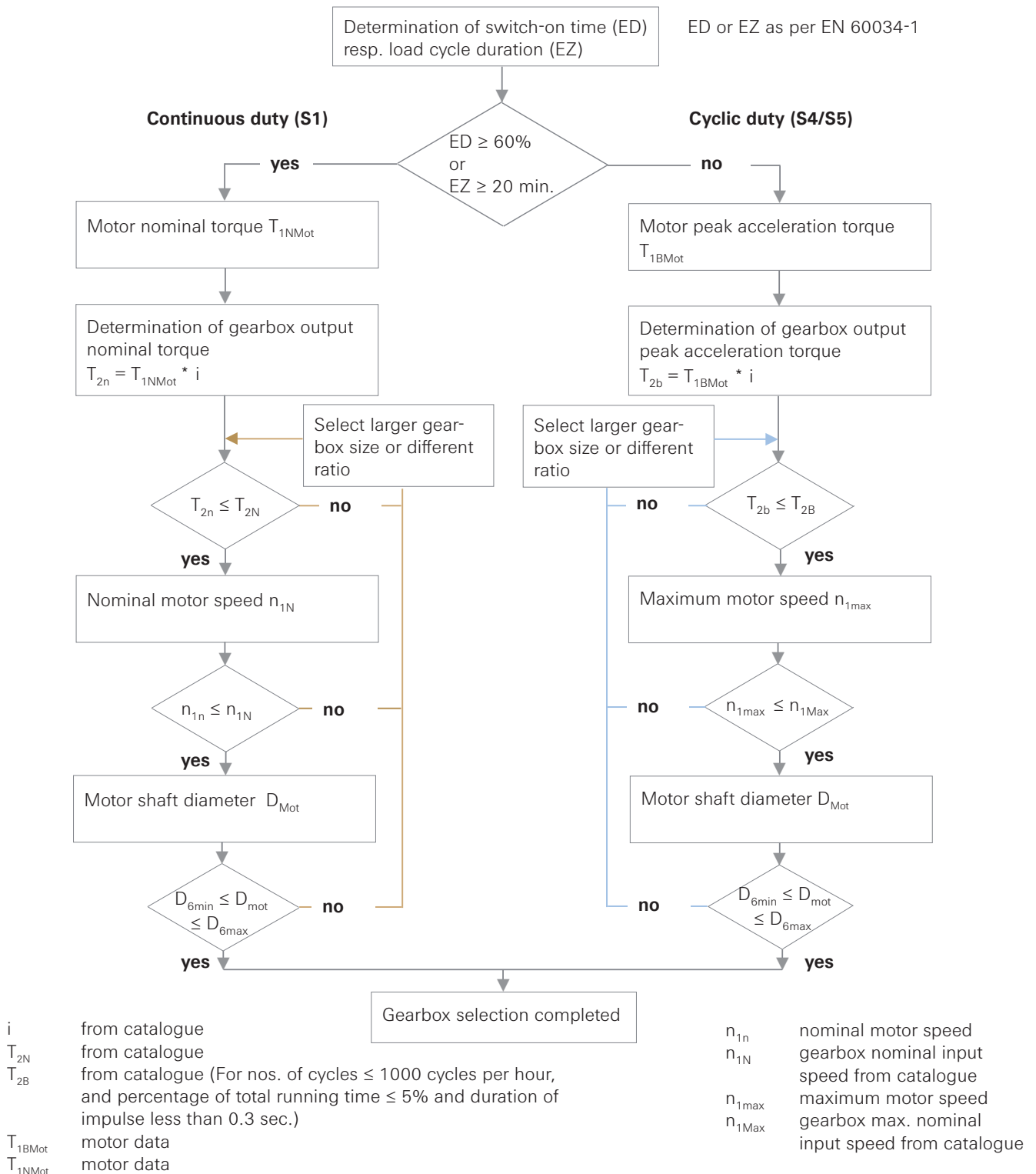

PG																0
	1	2	3	4	5	6	7	8	9	10	11	12	13			

ORDER NO.

Size	Size Code
PG 25/1, PG 25/2	002
PG 100/1, PG 100/2	010
PG 200/1, PG 200/2	020
PG 500/1, PG 500/2	050
PG 1200/1, PG 1200/2	120
PG 3000/1	300

Size	D7	D8	D9	L6 min	L6 max	L7	L22	Flange-Code
	[mm]	[mm]		[mm]	[mm]	[mm]	[mm]	
PG 25/1	30	45	M3	15	30	4	4.5	AA
PG 25/2	30	46	M4	15	30	4	4.5	AB
	36	70.7	M4	15	30	4	4.5	AC
	40	63	M4	15	30	3.5	4.5	AD
	40	63	M5	15	30	3.5	4.5	AE
	40	70	M4	15	30	3.5	4.5	AF
	50	60	M4	15	30	3.5	4.5	AG
	50	65	D5.5	15	30	3.5	4.5	AH
	50	70	M4	15	30	3.5	4.5	AI
	50	70	M5	15	30	3.5	4.5	AJ
	50	80	M5	15	30	4	4.5	AK
	50	95	M6	15	30	4	4.5	AL
	50	100	M6	15	30	3.5	4.5	AM
	60	75	M5	15	30	3.5	4.5	AN
	60	90	M5	15	30	4	4.5	AO
	70	90	M5	17	32	4	6.5	AP
	70	90	M5	19	34	5.5	8.5	AQ
	70	90	M6	15	30	3.5	4.5	AR
	73.05	98.5	M5	15	30	3	4.5	AS
	80	100	M6	15	30	3.5	4.5	AT
PG 100/1	50	95	M6	23	40	5.5	7.5	AA
PG 100/2	50	100	M6	23	40	5.5	7.5	AB
	60	75	M5	23	40	4.3	7.5	AC
	60	99	M6	23	40	4.3	7.5	AD
	70	90	M5	23	40	4.3	7.5	AE
	70	90	M6	23	40	4.3	7.5	AF
	80	100	M6	23	40	4.3	7.5	AG
	95	115	M8	23	40	4.3	7.5	AH
	95	130	M8	23	40	4.3	7.5	AI
	110	130	M8	23	40	4.3	7.5	AJ
	110	130	M8	34	51	4.3	18.5	AK
	110	145	M8	23	40	4.3	7.5	AL
	110	145	M8	34	51	6.5	18.5	AM
	110	145	M8	41	58	6.5	25.5	AN
	110	165	M10	34	51	4.3	18.5	AO
	80	100	M6	41	58	4.3	25.5	AP
	95	115	M8	41	58	4.3	25.5	AQ
	95	115	M8	27	44	6.3	11.5	AR
PG 200/1	95	115	M8	30	50	5.5	8.5	AA
PG 200/2	95	130	M8	30	50	5.5	8.5	AB
	110	130	M8	30	50	5.5	8.5	AC
	110	145	M8	30	50	6.5	8.5	AD
	110	145	M8	40	60	6.5	18.5	AE
	110	145	M8	45	65	6.5	23.5	AG
	110	165	M10	30	50	6.5	8.5	AH
	130	165	M10	40	60	6.5	18.5	AI
	80	100	M6	30	50	5.5	8.5	AJ
PG 500/1	110	145	M8	32	60	6.5	7.5	AA
PG 500/2	110	145	M8	38	66	6.3	13.5	AB
	110	165	M10	32	60	5.3	7.5	AC
	114.3	200	M12	32	60	5.3	7.5	AD
	114.3	200	M12	52	80	7.5	27.5	AE
	130	165	M10	32	60	5.3	7.5	AF
	130	165	M10	38	66	5.3	13.5	AG
	130	215	M12	32	60	5.3	7.5	AH
	180	215	M12	32	60	5.3	7.5	AI
	180	215	M12	52	80	5.3	27.5	AJ
PG 1200/1	114.3	200	M12	45	82	8	9	AA
	114.3	200	M12	76	113	8	40	AB
	130	215	M12	45	82	8	9	AC
	180	215	M12	45	82	8	9	AD
	200	235	M12	45	82	8	9	AE
	200	235	M12	79	116	8	43	AF
	230	265	M12	45	82	8	9	AG
	250	300	M16	45	82	8	9	AH
	250	300	M16	73	110	8	37	AI
PG 1200/2	110	145	M8	32	60	6.5	7.5	AJ
	110	145	M8	38	66	6.3	13.5	AK
	110	165	M10	32	60	5.3	7.5	AL
	114.3	200	M12	32	60	5.3	7.5	AM
	114.3	200	M12	52	80	7.5	27.5	AN
	130	165	M10	32	60	5.3	7.5	AO
	130	165	M10	38	66	6.3	13.5	AP
	130	215	M12	32	60	5.3	7.5	AQ
	180	215	M12	32	60	5.3	7.5	AR
	180	215	M12	52	80	5.3	27.5	AS
PG 3000/1	200	235	M12	61	116	8	15	AA
	242	300	M16	61	116	8	15	AB
	250	300	M16	55	110	8	9	AC
	300	350	M16	55	110	8	9	AD
	300	350	M16	85	140	8	39	AE

Output Flange	Type Code
Standard	A
Substitute	B

Backlash	Code
Standard	A
Reduced	B

Output Shaft	Code
Plain	0
Fitting key	1

i	Code
3	003*
4	004
5	005
7	007
10	010
20	020
25	025
35	035
40	040
50	050
70	070
100	100

* Available for gearbox size PG 200/1; PG 500/1; PG 1200/1; PG 3000/1

QUOTATION REQUEST?

Please fill out the questionnaire below and send to:

Fax: +49 7541 77-2379 or
 Email: industrial-drives@zf.com

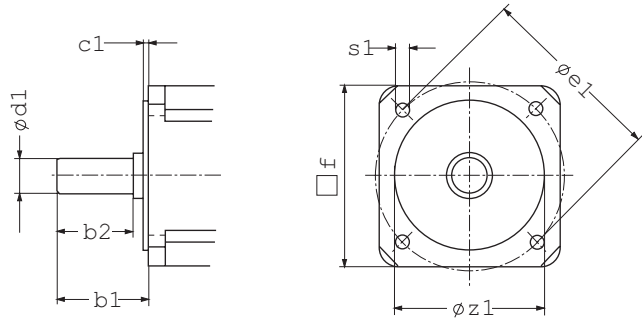

1. MOTOR DATA

Motor manufacturer _____

Type _____

Motor shaft diameter d1 [mm] _____

Flange face distance b1 [mm] _____

Motor shaft length b2 [mm] _____

Centering diameter z1 [mm] _____

Fixing hole circle diameter e1 [mm] _____

Fixing hole diameter s1 [mm] _____

Flange square f [mm] _____

Motor nominal torque [Nm] _____

Motor maximum torque [Nm] _____

2. GEARBOX DATA

ZF-Servoplan PG size **PG** _____

Ratio [i] _____

Keyed output shaft (yes / no) _____

Reduced backlash (yes / no) _____

Ordering number (page 11) **PG - - 0** _____

Basis of quotation (batch size) _____

Projected annual volume _____

Technical change without notice.

For studies, please request installation drawings; only the data contained therein is binding.

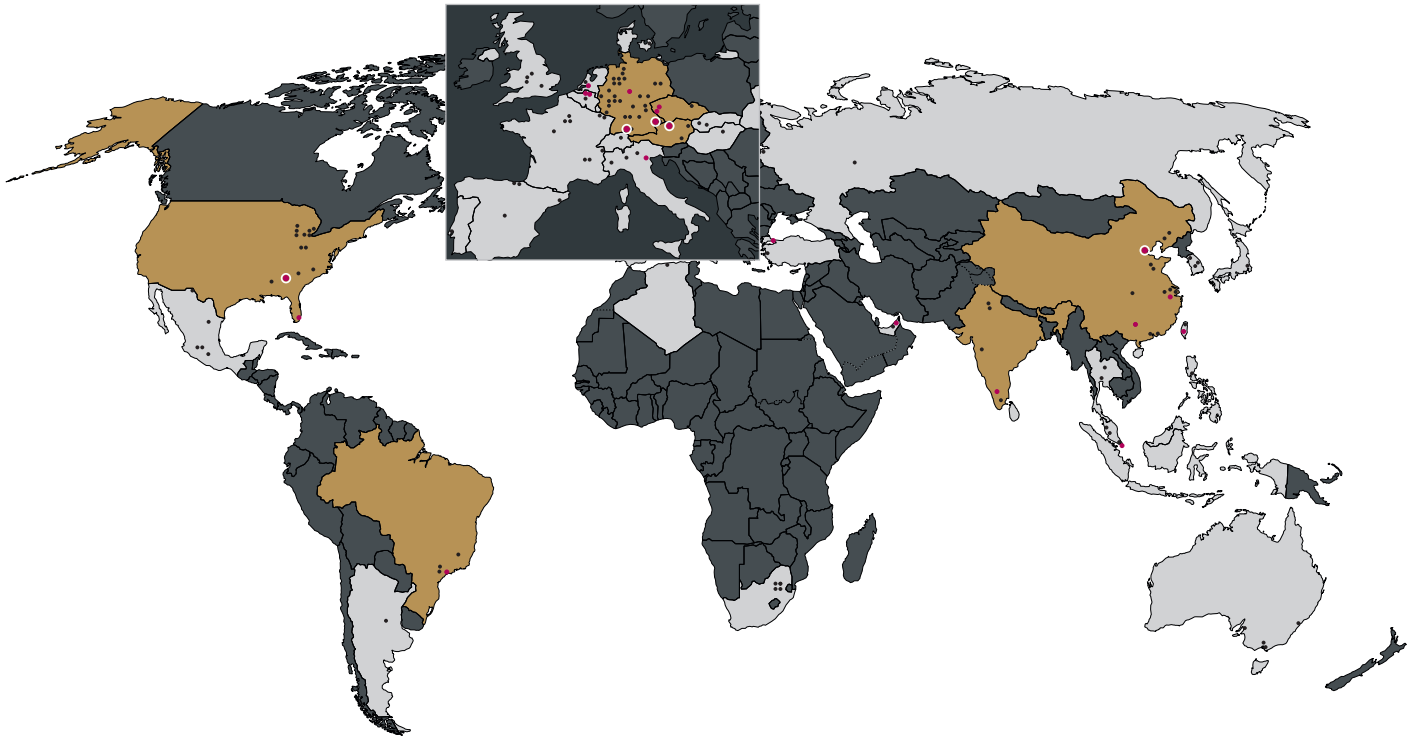

Excellentlly networked – worldwide

ZF offers you a comprehensive and attractive range of products and services to ensure mobility anywhere, at any time. Proximity to the customer is an essential element of the corporate performance.

The quality of innovative transmission systems is also a question of experience. For many decades, ZF transmissions have been a major impetus for on and off-road driving and technological progress.

ZF provides comprehensive system solutions all from a single source. The transmission components are perfectly harmonized with one another. The range of available power/performance is, in each case, tailored to the specific demands of the market and manufacturers.

The result: every ZF transmission system is a brand name product known for its reliability around the world.

Around the world, around the clock: ZF's service specialists are available anywhere and at any time.

SHARE *Responsibility* GLOBALLY

IMPROVE *Efficiency* PERMANENTLY

LEVERAGE *Opportunities* JOINTLY

DEMONSTRATE *Reliability* DAILY

ZF Friedrichshafen AG
Industrial Technology
Special Driveline Technology
Industrial Drives & Positioning Systems
88038 Friedrichshafen
Germany

Phone +49 7541 77-8403
Fax +49 7541 77-2379
E-Mail industrial-drives@zf.com



www.zf.com/industrial-drives



www.youtube.de/zffriedrichshafenag



Get to know more about the ZF products for industrial automation with the app "ZF XtraFair".
The mobile product catalog is available for iPad free of charge on the App StoreSM.



MOTION AND MOBILITY